

FP-00C-5D0

Fiber Optic RedLink® Transceiver Plug

Datasheet



DESCRIPTION

Firecomms Fiber Optic RedLink® Transceiver plugs can be assembled easily onto a Plastic Optical Fiber (POF) duplex cable to prepare it for use with Firecomms Fiber Optic RedLink® Transceiver. The Fiber Optic RedLink® Transceiver Plug offers a compact termination ideal for applications requiring robust plug retention and endurance against vibrations and mechanical shock.

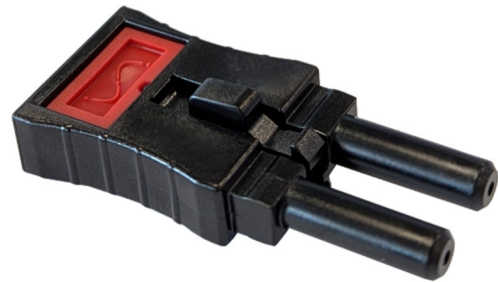

Table 1

ORDERING INFORMATION / PART NUMBERS

Part Number	Name	Description
FP-00C-5D0	Fiber Optic RedLink® Transceiver Plug	Black Plug

APPLICATIONS

- Control links within high voltage electrical control equipment
- Links between equipment that requires electrical isolation to be maintained
- Rugged links in hostile environments

FEATURES

- Cost-effective, rugged optical links
- High Retention Force
- Easy cable termination
- Suitable for use with RedLink® Transceiver family FB2M5PxR

SPECIFICATIONS

Table 2
Plug Specifications

Parameter	Symbol	Min	Typical	Max	Unit
Storage Temperature	T _{stg}	-40		+85	°C
Operating Temperature	T _{op}	-40		+85	°C
Installation Temperature	T _i	0		+70	°C
Retention Force, Connector to Transceiver; latching button pressed	F _{RP}	15	20		N
Retention Force, Connector to Transceiver; latching button NOT pressed	F _R		24		N
Insertion Force, Connector to Transceiver	F _I		20		N
Tensile Force, Connector to cable	F _C		90		N

Notes

1. Storage and operating temperatures refer to the ranges over which the plugs can be used when not subjected to mechanical stress. Installation temperature refers to the ranges which the plugs may be installed onto the fiber and over which the plugs can be connected and disconnected from the transceiver.
2. Typical data at 25°C
3. Caution – The latching mechanism release button should be pressed before attempting to disconnect the plug. If the connector is pulled out of the transceiver without pressing the lever, damage will occur.

MECHANICAL DIMENSIONS

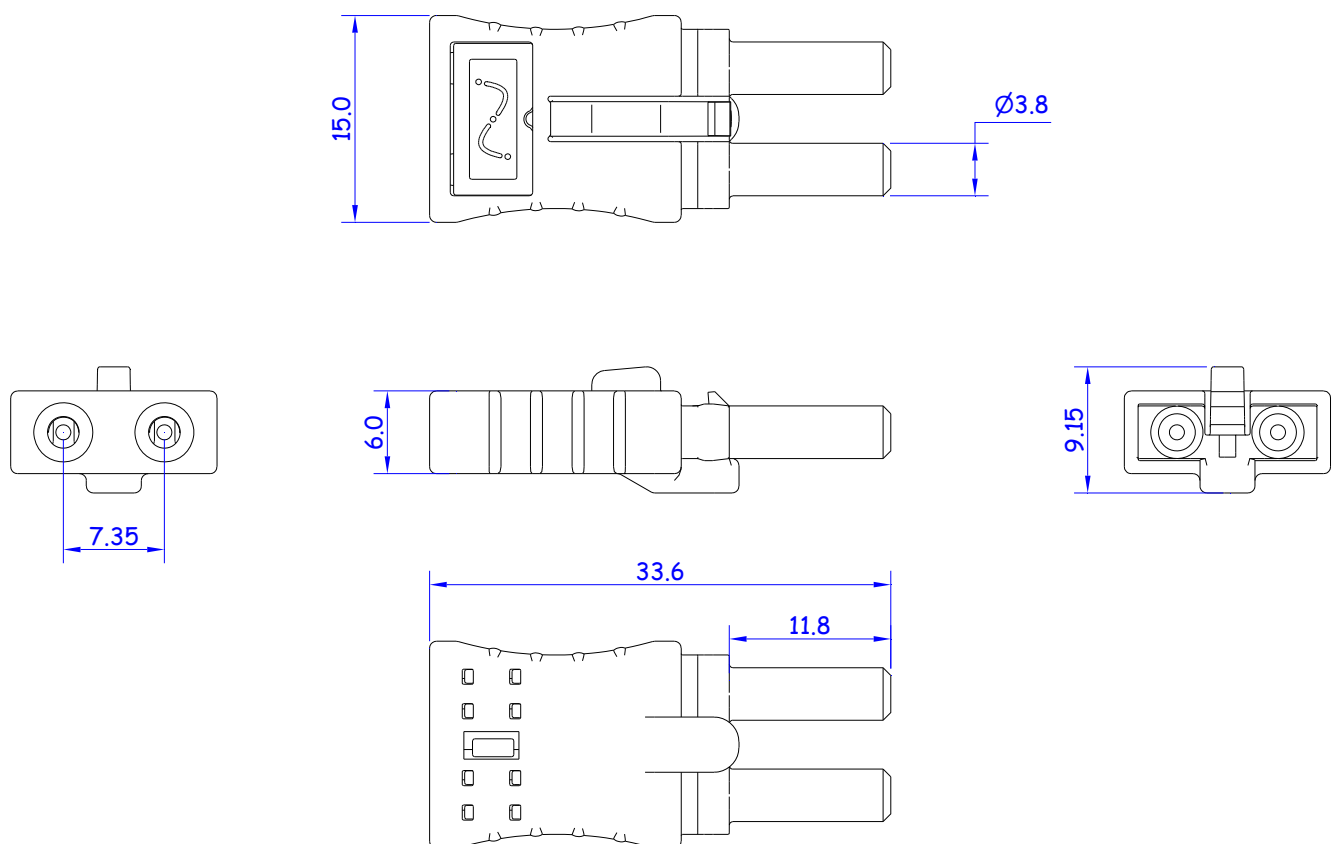

FIGURE 1
Fiber Optic RedLink® Transceiver Plug

CONNECTOR AND CABLE ASSEMBLY AND POLISHING

Cable Stripping

Strip off approximately 5 mm of the outer jacket from the 2.2 mm POF cable.



FIGURE 2
Jacket Strip Length

In order to strip the jacket from the POF, insert the cable into the hole at the bottom of the Firecomms POF cutter (PC-220F-410). After insertion, twist the cutter 360 degrees to cut the jacket and pull out the cable to reveal the exposed POF core.

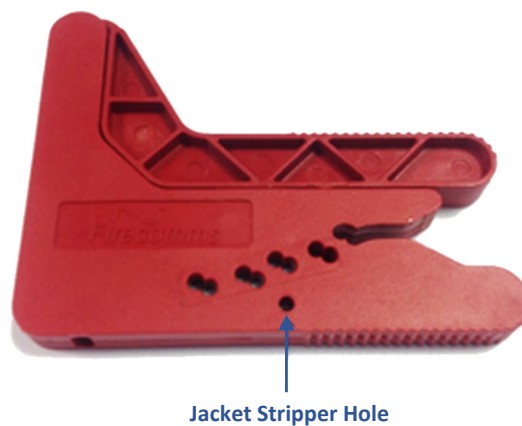

FIGURE 3
Jacket Stripper on POF Cutter

POF Insertion

Insert the stripped POF cable into the backside of the connector until the mechanical stop is reached. Approximately 1.5 mm of the POF internal core should protrude from the top of the connector.



FIGURE 4
Cable and Plug Positioning

Crimping Plug

Place the fiber clip lightly into place in the plug. Place the plug into a suitable assembly tool (FA-AST-BSU). Align the plug as shown in figure 5 below. Use the assembly tool to insert the fiber clip into the plug by actuating the assembly tool, ensuring the clip is fully inserted with the snap lock engaged. Ensure the Duplex Fiber plug is undamaged after assembly.

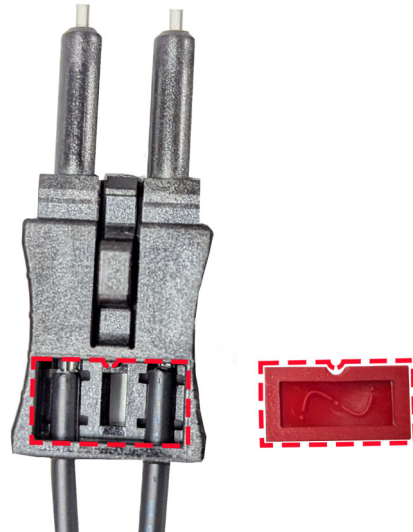

FIGURE 5
Secure Duplex Connector

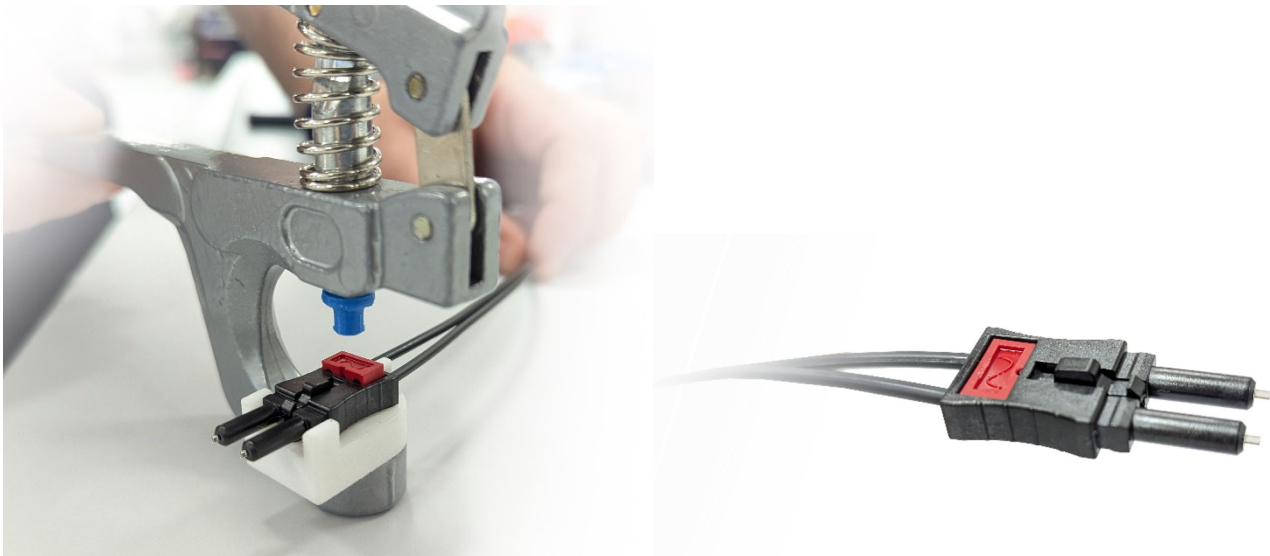

FIGURE 6
Secure Duplex Connector

Polishing

Insert the connector fully into a polishing disc. Press the disc on polishing paper (600 grit) and polish the fiber until it is flush with the connector. Rotate in a figure of 8 format which will erode the core material of the cable. Use a hard and plain support plate (e.g. glass plate).

After polishing, wipe the connector with a clean tissue removing foreign particles. Using 3 μ m grit, polish again for a smooth surface and wipe clean again. Best attenuation values are achieved by applying wet polishing.



FIGURE 7
Polishing Disc

For the most recent revision or further information please visit www.firecomms.com or contact the company directly at the following address, Firecomms Ltd, 2200 Airport Business Park, Cork, IRELAND. Copyright© 2004-2025 Firecomms. All rights reserved. Firecomms refers to Firecomms Limited and/or its subsidiaries. Firecomms assumes no responsibility for inaccuracies or omissions in the information contained in this document. Specifications are subject to change without notice. No patent rights are granted to any of the circuits described herein.